

System No. F-C-3071

F Rating - 1 Hr

T Rating - 1 Hr

FC3071

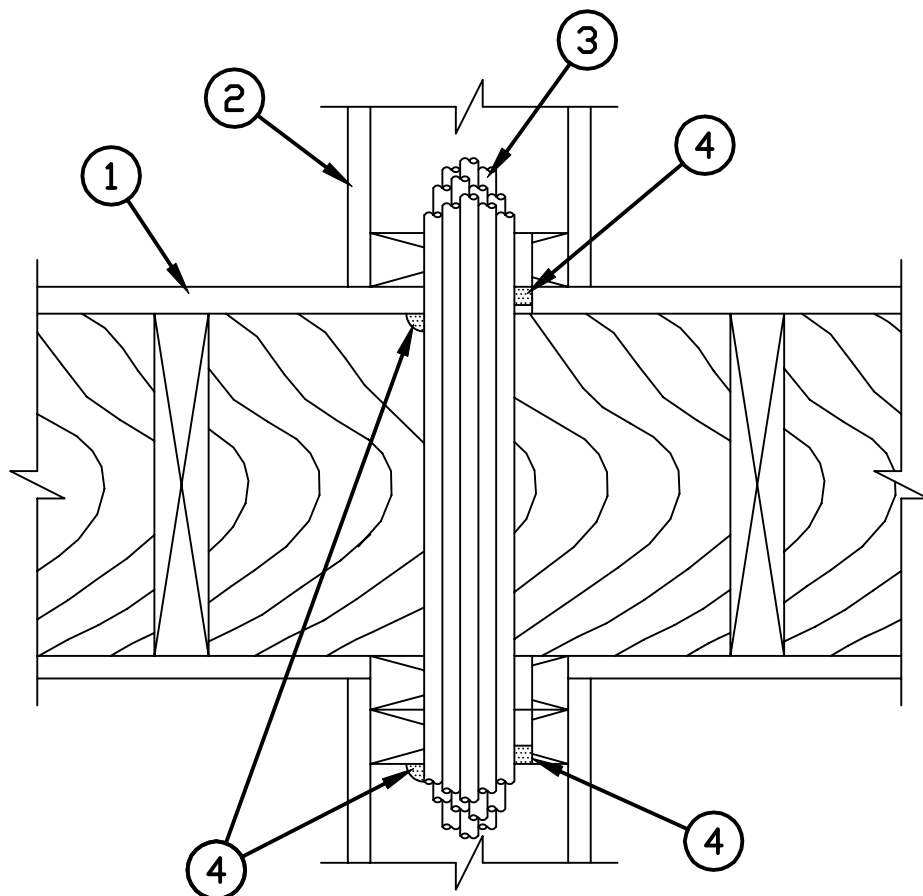

1. Floor-Ceiling Assembly - The 1 hr fire-rated solid or trussed lumber joist floor-ceiling assembly shall be constructed of the materials and in the manner specified in the individual L500 Series Floor-Ceiling Designs in the UL Fire Resistance Directory. The general construction features of the floor-ceiling assembly are summarized below:

- A. Flooring System - Lumber or plywood subfloor with finish floor of lumber, plywood or Floor Topping Mixture* as specified in the individual Floor-Ceiling Design. Max diam of opening shall be 3 in.
- B. Wood Joists* - Nom 10 in. deep (or deeper) lumber, steel or combination lumber and steel joists, trusses or Structural Wood Members* with bridging as required and with ends firestopped.
- C. Gypsum Board* - Nom 4 ft wide by 5/8 in. thick as specified in the individual Floor-Ceiling Design. Gypsum board secured to wood joists or furring channels as specified in the individual Floor-Ceiling Design.

HILTI[®]
FIRESTOP SYSTEMS

Reproduced by HILTI, Inc. Courtesy of
Underwriters Laboratories, Inc.
November 16, 2004



System No. F-C-3071

F Rating - 1 Hr

T Rating - 1 Hr

FC3071

2. Chase Wall - The through penetrants shall be routed through 1 hr fire-rated single, double or staggered wood stud/gypsum board chase wall constructed of the materials and in the manner specified in the individual U300 Series Wall and Partition Designs in the UL Fire Resistance Directory and shall include the following construction features:
- A. Studs - Nom 2 by 6 in. lumber studs.
 - B. Sole Plate - Nom 2 by 6 in. lumber plates. Max diam of opening is 3 in.
 - C. Top Plate - The double top plate shall consist of two nom 2 by 6 in. lumber plates. Max diam of opening is 3 in. D.
 - D. Gypsum Board* - Thickness, type, number of layers and fasteners shall be as specified in individual Wall and Partition Design.
3. Cables - Aggregate cross-sectional area of cable in opening to be max 45 percent of the cross-sectional area of the opening. The annular space between the cable bundle and the periphery of the opening to be min 0 in. (point contact) to max 1 in. Cables to be rigidly supported on both sides of the wall assembly. Any combination of the following types and sizes of copper conductor cables may be used:
- A. Max 25 pair No. 24 AWG telephone cable with PVC insulation and jacket.
 - B. Type RG 59/U coaxial cable with polyethylene (PE) insulation and PVC jacket.
 - C. Max 3/C with ground 2/0 AWG aluminum conductor SER cable with PVC insulation and jacket.
 - D. Max 3/C No. 8 AWG copper conductor steel clad cable.
 - E. Max 3/C No. 10 with ground Type NM nonmetallic sheathed (Romex) cable with PVC insulation and jacket.
 - F. Max 1 in. diam metal clad TEK cable with PVC jacket.
4. Fill, Void or Cavity Materials*-Sealant - Min 1/2 in. thickness of fill material applied around through penetrant within the annulus on top surface of floor or sole plate of chase wall. Min 1/2 in. thickness of fill material applied within the annulus of the top plate flush with the bottom surface of the lower top plate. Min 1/2 in. bead of fill material applied at the penetrant/lumber interfaces at point contact locations on bottom surface of plywood or top surface of sole plate, and bottom surface of lower top plate.

HILTI CONSTRUCTION CHEMICALS, DIV OF HILTI INC - CP 606 Flexible Firestop Sealant

*Bearing the UL Classification Mark



Reproduced by HILTI, Inc. Courtesy of
Underwriters Laboratories, Inc.
November 16, 2004

