

## System No. F-C-7025

F Rating -- 1 Hr

T Rating -- 0 Hr

FC 7025

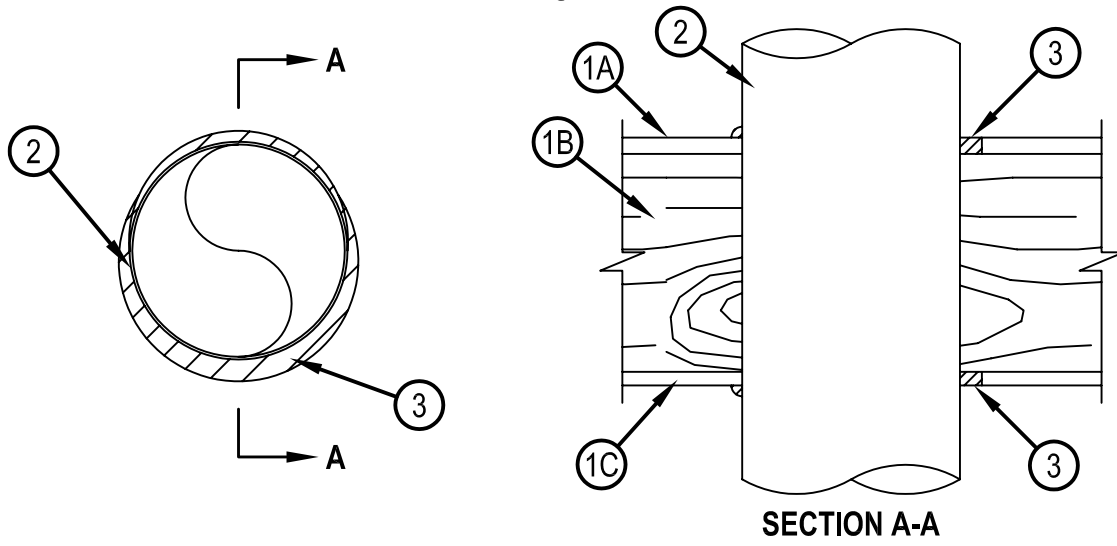

1. Floor-Ceiling Assembly -- The 1 hr fire-rated solid or trussed lumber joist floor-ceiling assembly shall be constructed of the materials and in the manner specified in the individual L500 Series Floor-Ceiling Designs in the UL Fire Resistance Directory. The general construction features of the floor-ceiling assembly are summarized below:

- A. Flooring System -- Lumber or plywood subfloor with finish floor of lumber, plywood or Floor Topping Mixture\* as specified in the individual Floor-Ceiling Design. Max diam of opening shall be 11 in. (279 mm).
- B. Wood Joists\* -- Nom 10 in. (254 mm) deep (or deeper) lumber, steel or combination lumber and steel joists, trusses or Structural Wood Members\* with bridging as required and with ends firestopped.
- C. Gypsum Board\* -- Nom 4 ft (1.22 m) wide by 5/8 in. (16 mm) thick as specified in the individual Floor-Ceiling Design. Gypsum board secured to wood joists or furring channels as specified in the individual Floor-Ceiling Design. Max diam of opening shall be 11 in. (279 mm).

1A. Chase Wall -- (Optional, Not Shown) -- The through penetrants (Item 2) may be routed through a 1 hr fire rated single, double or staggered wood stud/gypsum board chase wall. Depth of chase wall stud cavity to be min 1/2 in. (13 mm) greater than diameter of opening cut in sole and top plates to accommodate the through penetrant (Item 2). The chase wall shall be constructed of the materials and in the manner specified in the individual U300 Series Wall and Partition Designs in the UL Fire Resistance Directory and shall include the following construction features:

- A. Studs -- Nom 2 by 4 in. (51 by 102 mm), 2 by 6 in. (51 by 152 mm), 2 by 10 in. (51 by 254 mm) or 2 by 12 in. (51 by 305 mm) lumber studs or double min 2 by 4 in. lumber studs.
- B. Sole Plate -- Nom 2 by 4 in. (51 by 102 mm), 2 by 6 in. (51 by 152 mm) 2 by 10 in. (51 by 254 mm) or 2 by 12 in. (51 by 305 mm) lumber plates or parallel min 2 by 4 in. (51 by 102 mm) lumber plates, tightly butted. Max diam of opening is 11 in. (279 mm).
- C. Top Plate -- The double top plate shall consist of two nom 2 by 4 in. (51 by 102 mm), two nom 2 by 6 in. (51 by 152 mm), two nom 2 by 10 in. (51 by 254 mm) or two nom 2 by 12 in. (51 by 305 mm) lumber plates or two sets of parallel min 2 by 4 in. (51 by 102 mm) lumber plates, tightly butted. Max diam of opening is 11 in. (279 mm).
- D. Gypsum Board\* -- Thickness, type, number of layers and fasteners shall be as specified in the individual Wall and Partition Design.

2. Steel Duct -- One steel duct to be installed concentrically or eccentrically within the opening. The annular space between the steel duct and the periphery of opening shall be min 0 in. (0 mm, point contact) to max 1 in. (25 mm). Steel duct to be rigidly supported on both sides of floor-ceiling assembly. The following sizes of steel ducts may be used:

- A. Max 10 in. (254 mm) diam by min 0.019 in. (0.50 mm) thick steel duct.
- B. Max 4 in. (102 mm) diam by min 0.016 in. (0.40 mm) thick steel duct.

3. Fill, Void or Cavity Materials\*-Sealant -- Min 3/4 in. (19 mm) thickness of sealant applied within the annulus flush with the top surface of the floor or sole plate. Min 5/8 in. (16 mm) thickness of sealant applied within the annulus flush with the bottom surface of gypsum board or lower top plate. A min 1/2 in. (13 mm) diam bead of sealant to be applied at the duct/subflooring or sole plate interface and the duct/gypsum board or top plate interface.

HILTI CONSTRUCTION CHEMICALS, DIV OF HILTI INC -- CP 606 Flexible Firestop Sealant

\*Bearing the UL Classification Mark

**HILTI**<sup>®</sup>  
**FIRESTOP SYSTEMS**

Reproduced by HILTI, Inc. Courtesy of  
Underwriters Laboratories, Inc.  
August 10, 2005

